

BF 135.8

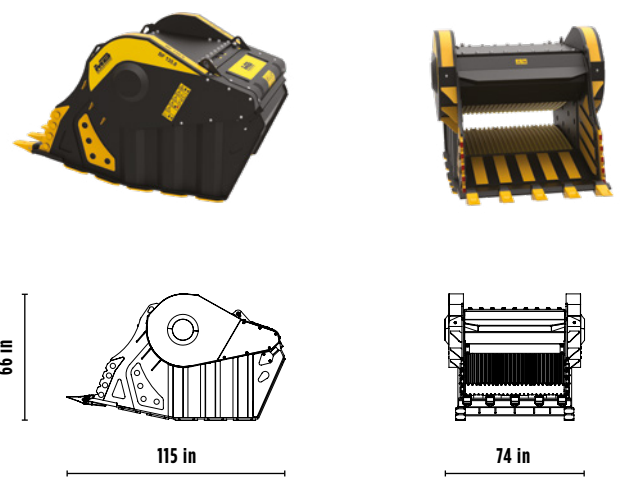

ACCESSORIES

- RECOMMENDED SPARE PARTS KIT
- FIXED COUPLING
- IRON SEPARATOR
- HOUR METER
- DUST SUPPRESSION KIT
- 24 MONTHS WARRANTY



SPECIFICATIONS

EQUIPMENT	≥ 94,800 ≤ 176,400 lb
LOAD CAPACITY	2.09 cy
OPENING DIMENSIONS	W 51 H 24 in
OUTPUT SETTING	≥ 1 ≤ 6 in
DIMENSIONS	115" x 74" x 66" H in
OIL FLOW	> 85 < 100 gal/min
PRESSURE	> 3,336 PSI
WEIGHT	16,535 lbs

AREAS OF APPLICATION

RECYCLING

LARGE-SCALE
URBAN SITES

QUARRIES

MINES

UTILITY
WORK

DEMOLITION

The data provided above is not binding, as the manufacturer reserves itself the right to make improvements to its products at any time and with no advance notice. References to excavator weights are approximate and many may be subject to changes.