

MB-LS140

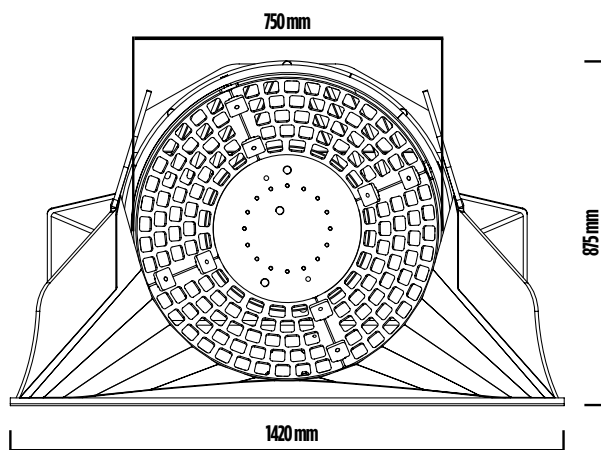

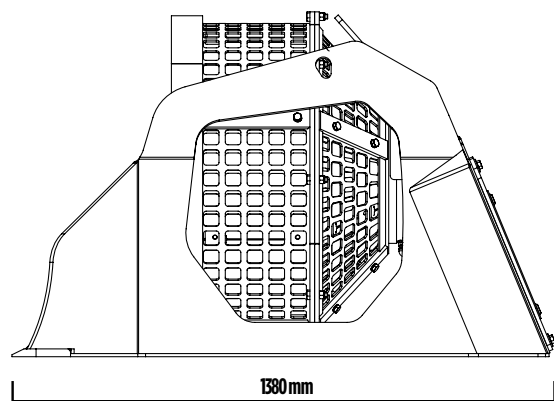
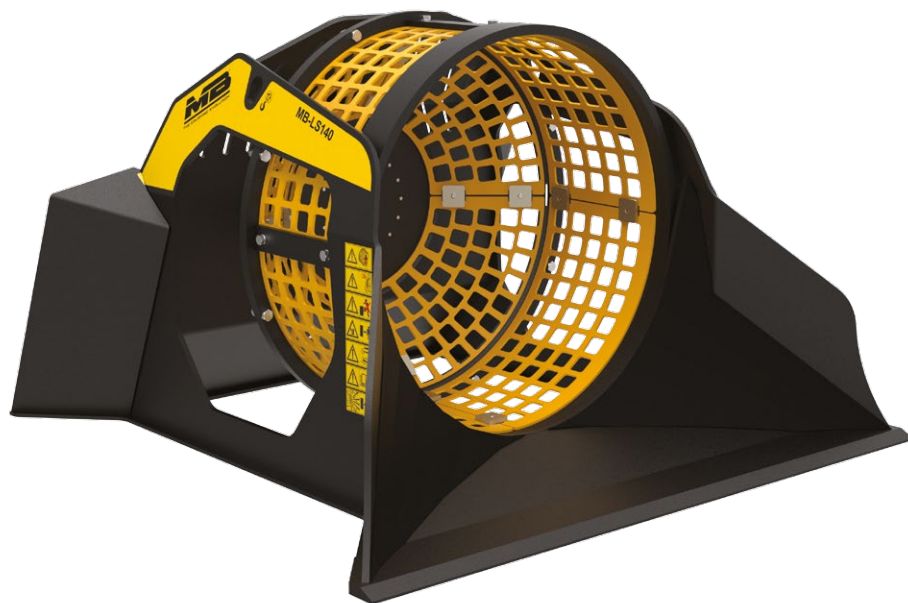
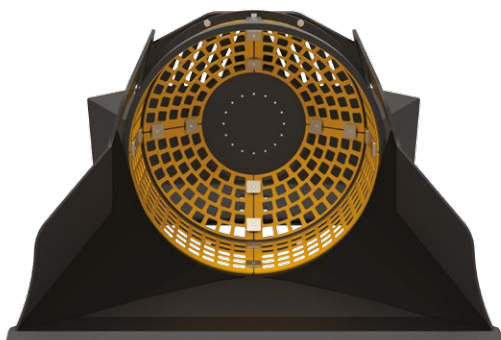

MB-LS140

Designed to be used with mini-excavators and small loaders, the MB-LS140 screening bucket is the smallest in the MB range. Combined usage with Mb crusher buckets allows for a reduction of up to 60% in terms of crushing time, immediately recycling desired size materials.



PRIMARY SELECTION:

- WASTE MATERIAL
- DEMOLITION MATERIAL
- EXCAVATION FILLING MATERIAL
- STONY GROUND RECLAIM
- PEBBLES IN STREAMS
- DEBRIS IN BEACHES
- NATURAL STONE S CLEANING

ACCESSORIES

- RECOMMENDED SPARE PARTS KIT
- HOUR METER
- 24 MONTHS WARRANTY

AREAS OF APPLICATION

- RECYCLING
- SMALL URBAN WORKSITES
- DEMOLITION

SPECIFICATIONS

EQUIPMENT	LOAD CAPACITY	BASKET DEPTH	GRID DIAMETER	DIMENSIONS
 ≥ 2,6 Ton	0,40 m ³	560 mm	750 mm	1380 x 1420 H 875 mm
OIL FLOW	PRESSURE	COUNTER PRESSURE DRAIN	WEIGHT	SPEED/MIN.
40 l/min.	130 bar	-	0,45 Ton	25/30 min/max