

MB-L140 S2

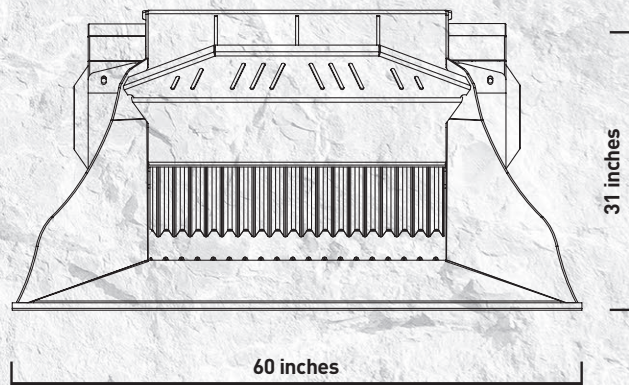

“Compact with performance”

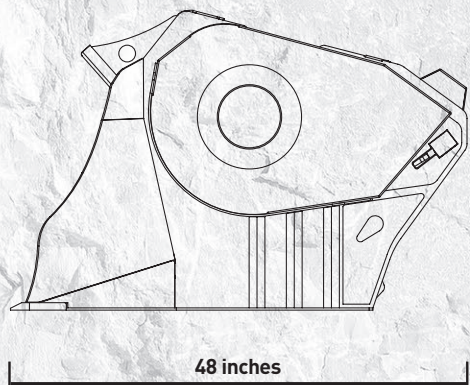

It's small, compact, and easy to handle. This machine offers the highest standards of productivity and quality.

The MB-L140 S2 crusher bucket is suitable for skid loaders starting at a machine weight of 6,600 pounds and backhoe loaders starting at a machine weight between 13,200 and 17,600 pounds.

It has a load capacity of 0.30 cubic yards and a production rate from 10 cy/h to 21 cy/h.

This bucket is the perfect combination of versatility, performance, and practicality.



AREAS OF APPLICATION

- DEMOLITION
- RECYCLING
- ROAD WORKS
- EXCAVATION

SPECIFICATIONS

EQUIPMENT	LOAD CAPACITY	OPENING DIMENSIONS	OUTPUT SETTING	DIMENSIONS
SKID LOADER ≥ 6,600 lbs BACKHOE LOADER / LOADER 13,200-17,600 lbs	0.30 cy	29" W x 10" H in	≥ 0.5 in ≤ 2.5 in	48" x 60" x 31" H in
OIL FLOW	PRESSURE	COUNTER PRESSURE	WEIGHT	MAXIMUM PRODUCTION
26 gal/min.	2,900 PSI	< 145 PSI	2,161 lbs	21 cy/h

ACCESSORIES

RECOMMENDED SPARE PARTS KIT	FIXED COUPLER	QUICK FEMALE COUPLER	IRON SEPARATOR	HR METER
MBL140015	-	-	-	804MBNF01
			DUST SUPPRESSION KIT	OPTIONAL 24 MONTHS WARRANTY
			KNMB00L-KNMB00S-KNMB00M	WA241401

The data provided above is not binding, as the manufacturer reserves itself the right to make improvements to its products at any time and with no advance notice. References to excavator weights are approximate and many may be subject to changes. Consider a 20% tolerance.