

MB-G1200

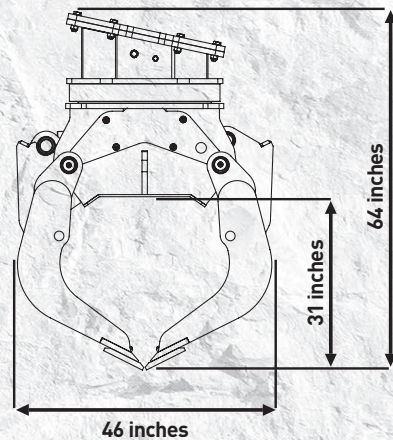

“Great performance”

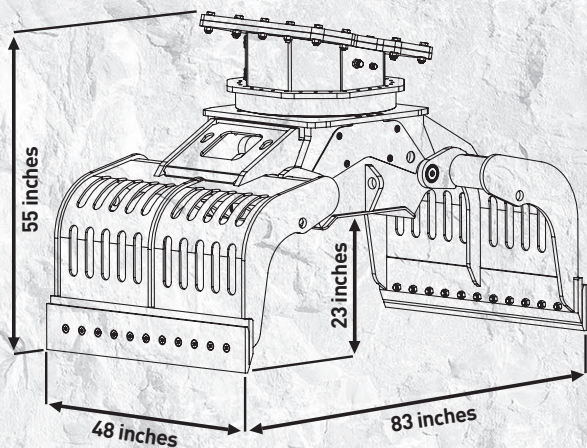
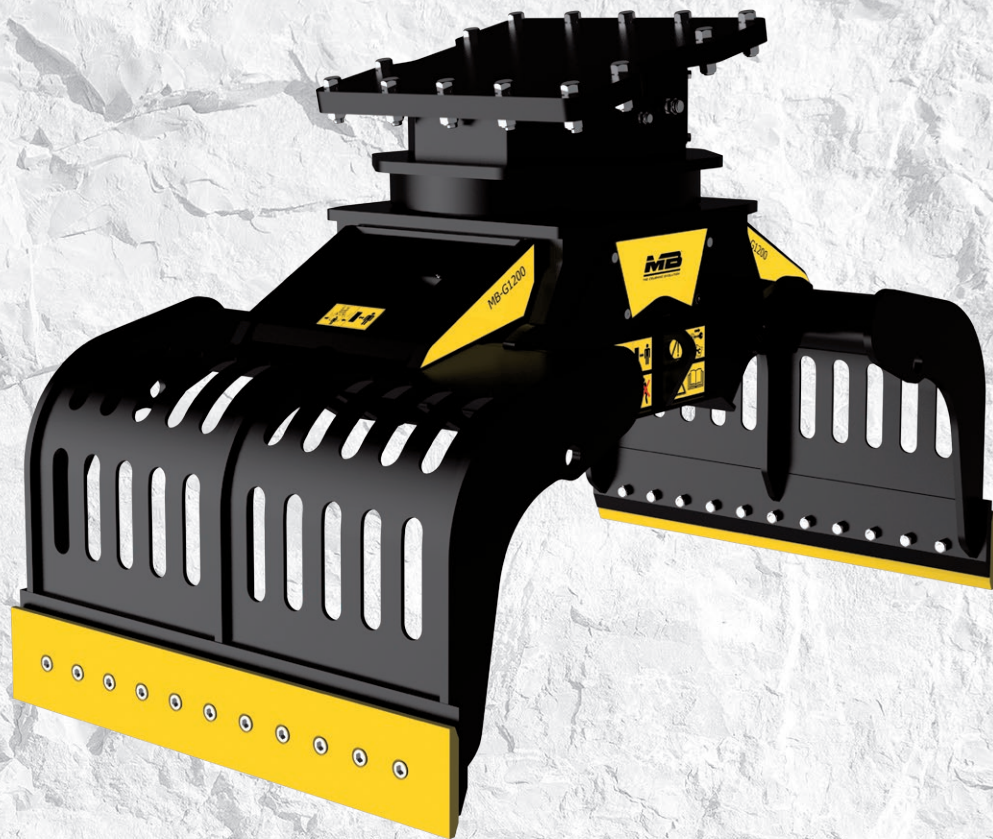

Designed for selecting and handling demolition materials and manufactured according to the highest technological standards for any type of materials in a reliable way.

Thanks to the interchangeable claws and the 360° hydraulic rotation, it allows you to handle large loads and odd forms with certainty and total safety.

SPECIFICATIONS

RECOMMENDED EXCAVATOR	LOAD CAPACITY (CLAWS CLOSED)		OIL FLOW (OPEN/CLOSE)
39,600-55,000 lbs	25 ft ³		13.2 gal/min.
PRESSURE (OPEN/CLOSE)	WEIGHT		ROTATION
4,300 PSI / 5,800 PSI	3,500 lbs		360°

ACCESSORIES

RECOMMENDED SPARE PARTS KIT	FIXED COUPLER	QUICK FEMALE COUPLER	
MBG120008	FCG121500	MBG121500	
			OPTIONAL 24 MONTHS WARRANTY
			WA241200