

BF 135.8

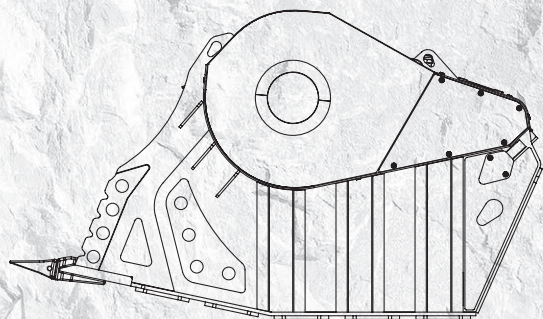

115 inches

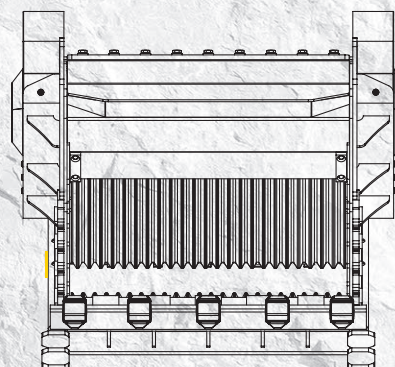

74 inches

66 inches

“Inexhaustible power”



Suitable for excavators weighing over 94,000 pounds, the crusher bucket BF 135.8 was created to meet the specific needs of crushing in quarries, for aggregate recycling operations in landfills, and for volume reduction of materials from demolition sites of large yards, excavation, or sewage systems.

With a production rate from 51 cy/h to 115 cy/h, a load capacity of 2.00 cubic yards, and a total weight of 16,500 pounds, the crusher bucket BF 135.8 is a versatile powerhouse.



AREAS OF APPLICATION

QUARRIES
DEMOLITION
RECYCLING
EXCAVATION
MINES
ROAD WORKS

SPECIFICATIONS

RECOMMENDED EXCAVATOR	LOAD CAPACITY	OPENING DIMENSIONS	OUTPUT SETTING	DIMENSIONS
≥ 94,000 lbs	2.00 cy	51" W x 23" H in	≥ 1.5 in ≤ 6.0 in	115" x 74" x 66" H in
OIL FLOW	PRESSURE	COUNTER PRESSURE	WEIGHT	MAXIMUM PRODUCTION
85 gal/min.	3,600 PSI	< 145 PSI	16,500 lbs	115 cy/h

ACCESSORIES

RECOMMENDED SPARE PARTS KIT	FIXED COUPLER	QUICK FEMALE COUPLER	IRON SEPARATOR	OUR METER
BF1308015	FC1380000	-	-	804MBNF01
			DUST SUPPRESSION KIT	OPTIONAL 24 MONTHS WARRANTY
			-	WA2413080