

# BF 90.3 S3

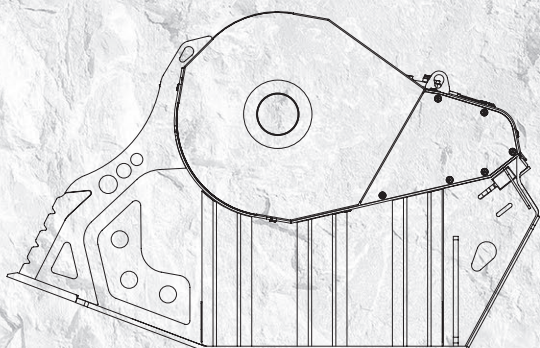

86 inches

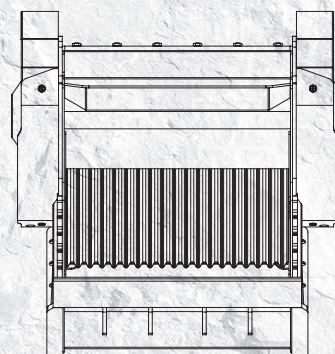

52 inches

54 inches

# “The bucket that made **history**”



The first crusher bucket, produced and patented by MB in 2001, is still the most popular model for medium- to large-sized companies.

Renewed and improved over the years, the BF 90.3 S3 is suitable for excavators over 46,300 pounds in weight. It is compact, versatile, and ideal for all types of recycling operations, road work, pipelines, demolition, and excavation.

The BF 90.3 S3 weighs over 7,000 pounds and has a load capacity of 1.18 cubic yards. Despite its size and weight compared to the larger models, it achieves a production rate from 16 cy/h to 54 cy/h, depending on the output adjustment.



## AREAS OF APPLICATION

- QUARRIES
- DEMOLITION
- RECYCLING
- EXCAVATION
- MINES
- ROAD WORKS

## SPECIFICATIONS

RECOMMENDED EXCAVATOR	LOAD CAPACITY	OPENING DIMENSIONS	OUTPUT SETTING	DIMENSIONS
≥ 46,300 lbs	1.18 cy	35.8" W x 21" H in	≥ 0.75 in ≤ 5.0 in	86" x 52" x 54" H in
OIL FLOW	PRESSURE	COUNTER PRESSURE	WEIGHT	MAXIMUM PRODUCTION
47.5 gal/min.	3,190 PSI	< 145 PSI	7,717 lbs	54 cy/h

## ACCESSORIES

RECOMMENDED SPARE PARTS KIT	FIXED COUPLER	QUICK FEMALE COUPLER	IRON SEPARATOR	OUR METER
BF9030078	FC9030000	BF9030000	BF9030017	804MBNF01
			DUST SUPPRESSION KIT	OPTIONAL 24 MONTHS WARRANTY
			KNMB00L-KNMB00S-KNMB00M	WA249030

The data provided above is not binding, as the manufacturer reserves itself the right to make improvements to its products at any time and with no advance notice. References to excavator weights are approximate and many may be subject to changes. Consider a 20% tolerance.