

BF 80.3

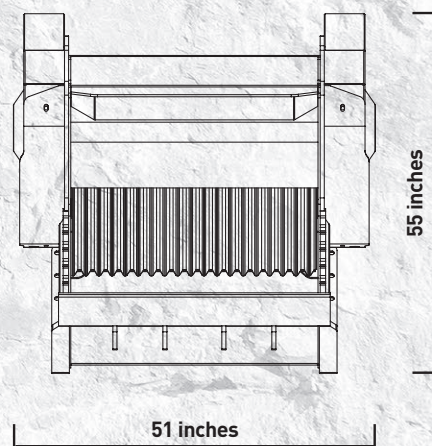

“Light and **reliable**”

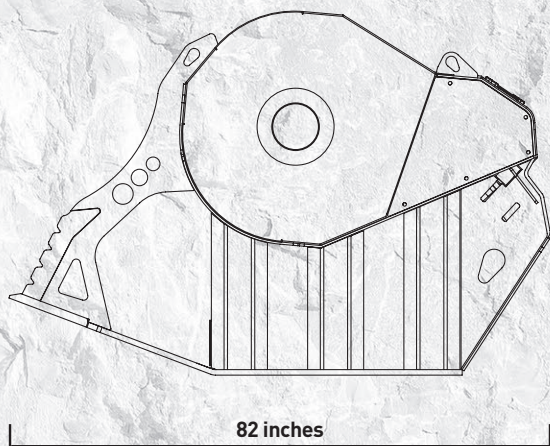

Suitable for excavators at a starting weight of 40,700 pounds, the crusher bucket BF 80.3 is compact, versatile, and ideal for the operations of crushing and recycling of inert material, or material from demolition sites (road works - excavations - pipes - pipelines).

The BF 80.3 weighs over 6,000 pounds and has a load capacity of 1.00 cubic yard. Despite its size and lower weight compared to larger models, it has a production rate between 13 cy/h and 45 cy/h, depending on the output adjustment.

AREAS OF APPLICATION

- QUARRIES
- DEMOLITION
- RECYCLING
- EXCAVATION
- MINES
- ROAD WORKS

SPECIFICATIONS

RECOMMENDED EXCAVATOR	LOAD CAPACITY	OPENING DIMENSIONS	OUTPUT SETTING	DIMENSIONS
≥ 40,700 lbs	1.00 cy	33" W x 20" H in	≥ 0.75 in ≤ 5.0 in	82" x 51" x 55" H in
OIL FLOW	PRESSURE	COUNTER PRESSURE	WEIGHT	MAXIMUM PRODUCTION
43 gal/min.	3,100 PSI	< 145 PSI	6,600 lbs	45 cy/h

ACCESSORIES

RECOMMENDED SPARE PARTS KIT	FIXED COUPLER	QUICK FEMALE COUPLER	IRON SEPARATOR	OUR METER
BF8030010	FC8030000	BF8030000	BF8030017	804MBNF01
			DUST SUPPRESSION KIT	OPTIONAL 24 MONTHS WARRANTY
			KNMB00L-KNMB00S-KNMB00M	WA248030

The data provided above is not binding, as the manufacturer reserves itself the right to make improvements to its products at any time and with no advance notice. References to excavator weights are approximate and many may be subject to changes. Consider a 20% tolerance.