

# BF 60.1

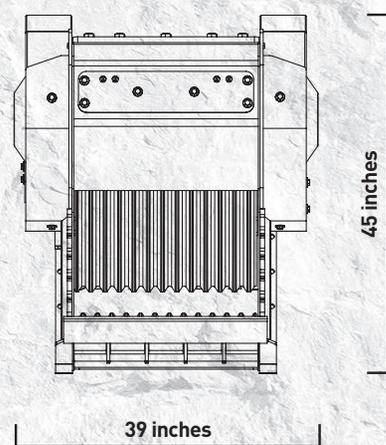

# “Small but for **great needs**”

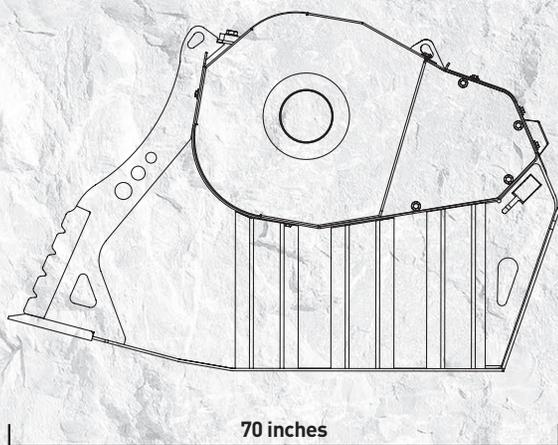

The BF 60.1 crusher bucket, regardless of the crushing job, is able to work in urban construction sites and limited work spaces.

Suitable for excavators starting from 19,800 pounds, the BF 60.1 weighs a little over 3,300 pounds and has a load capacity of 0.80 cubic yards.

The mouth opening measures at 25 inches W by 21 inches H to ensure an optimal production rate from 9 cy/h to 26 cy/h, depending on the crushing output.



## AREAS OF APPLICATION

DEMOLITION  
RECYCLING  
EXCAVATION  
ROAD WORKS

## SPECIFICATIONS

RECOMMENDED EXCAVATOR	LOAD CAPACITY	OPENING DIMENSIONS	OUTPUT SETTING	DIMENSIONS
≥ 19,800 lbs	0.80 cy	25" W in x 21" H in	≥ 0.75 in ≤ 4.5 in	70" x 39" x 45" H in
OIL FLOW	PRESSURE	COUNTER PRESSURE	WEIGHT	MAXIMUM PRODUCTION
26 gal/min.	3,046 PSI	< 145 PSI	3,307 lbs	26 cy/h

## ACCESSORIES

RECOMMENDED SPARE PARTS KIT	FIXED COUPLER	QUICK FEMALE COUPLER	IRON SEPARATOR	HR METER
BF6010028	FC6010000	BF6010000	BF6010010	804MBNF01
			DUST SUPPRESSION KIT	OPTIONAL 24 MONTHS WARRANTY
			KNMB00L-KNMB00S-KNMB00M	WA246010