

MB-LS170

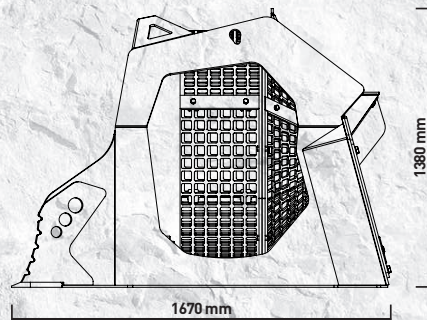

“Innovative and Handy”

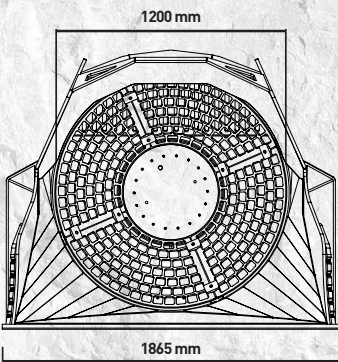
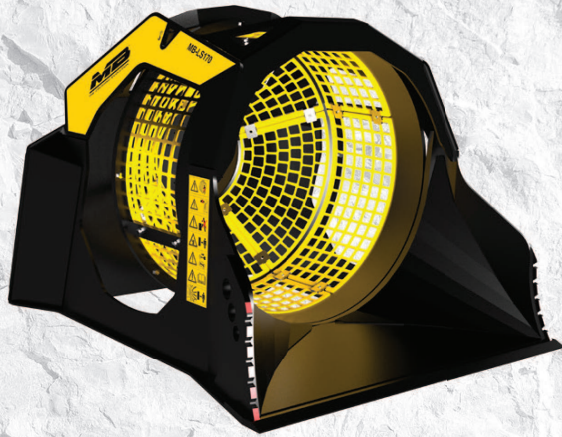
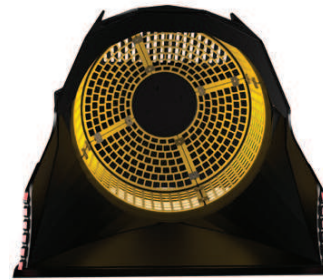

Ideal for natural material selection either pre or post crushing stage, the screening MB-LS170 allows to cut down up to 60% of the crushing time and to recover material suitable to the type of processing desired to handle it in the best way.

Particularly suitable for wheel loader and backhoe from 6.5 to 11 ton.

PRIMARY SELECTION:

- WASTE MATERIAL
- DEMOLITION MATERIAL
- EXCAVATION FILLING MATERIAL
- STONY GROUND RECLAIM
- PEBBLES IN STREAMS
- DEBRIS IN BEACHES
- NATURAL STONE S CLEANING

SPECIFICATIONS

| EQUIPMENT | LOAD CAPACITY | BASKET DEPTH | GRID DIAMETER | DIMENSIONS |
|---|---------------------|---------------------------|---------------|-----------------------|
| BACKHOE LOADER / LOADER ≥ 6,5 ≤ 11 Ton | 1,10 m ³ | 890 mm | 1200 mm | 1670 x 1865 H 1380 mm |
| OIL FLOW | PRESSURE | COUNTER PRESSURE DRAIN | WEIGHT | SPEED/MIN. |
| 60 l/min. | 150 bar | - | 1,35 Ton | 25/35 min/max |

ACCESSORIES

| RECOMMENDED SPARE PARTS KIT | FIXED COUPLER | QUICK FEMALE COUPLER | HOUR METER | |
|--------------------------------|---------------|-------------------------|------------|---------------------------|
| MBLS17012 | - | - | 804MBBV01 | |
| | | | | 24 MONTHS WARRANTY |
| | | | | WA241700 |