

# MB-G1500

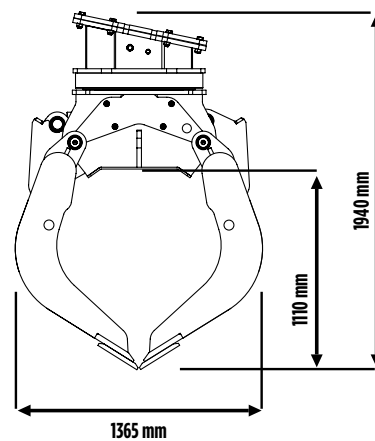

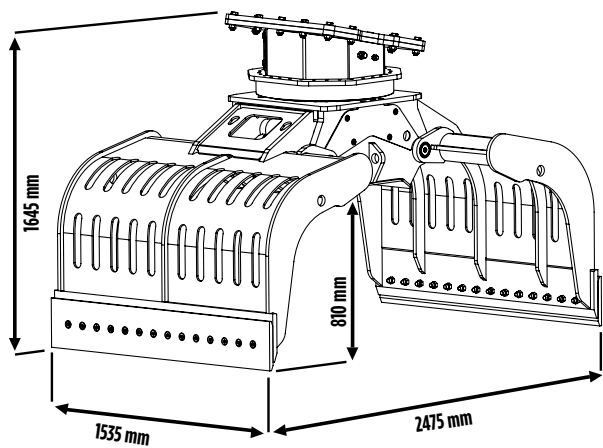

## MB-G1500

The MB-G1500 grapple, the largest in the range, has been created to be used on sites which require handling of large-sized materials, such as, the loading and unloading of containers. It combines notable operational agility, extreme sensitivity and hold precision, and its closing strength can be gradually increased to the point of carrying out demolitions of walls.

## ACCESSORIES

RECOMMENDED SPARE PARTS KIT  
FIXED COUPLER  
QUICK FEMALE COUPLER  
24 MONTHS WARRANTY

## AREAS OF APPLICATION

PORTS AND FREIGHT HANDLING HUBS  
URBAN JOB SITES  
DEMOLITION

## SPECIFICATIONS

EQUIPMENT	LOAD CAPACITY (CLAWS CLOSED)	FLOW DIRECTION	OIL FLOW (OPEN/CLOSE)
 ≥ 20 ≤ 25 Ton	1,43 m <sup>3</sup> / 1430 L	25 ÷ 40 l/min.	50 l/min.
PRESSURE OF ROTATION	PRESSURE (OPEN/CLOSE)	WEIGHT	ROTATION
200 bar	300 ÷ 400 bar	2 Ton	360°