

MB-LS220

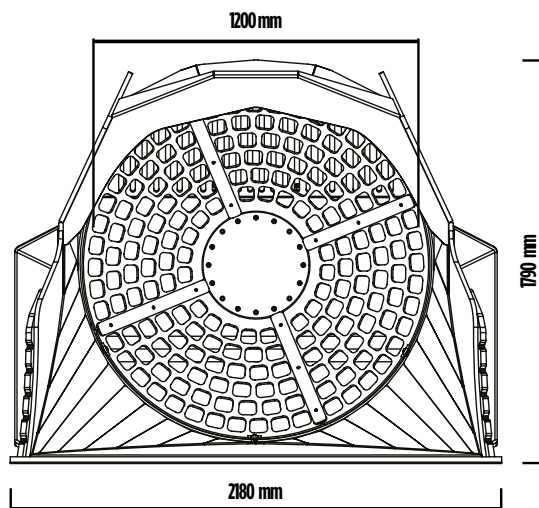

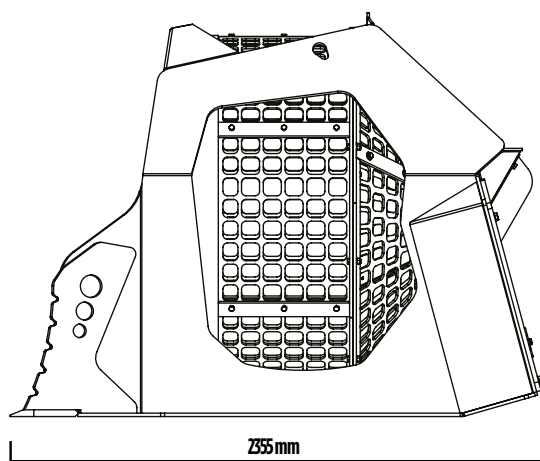
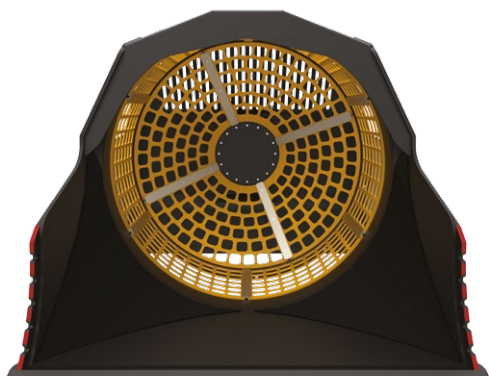

MB-LS220

The MB-LS220 screening bucket is the largest in the range and is ideal for the selection of natural materials in quarries, mines and large-scale sites. Particularly flexible, it facilitates quick material processing in all areas of the site. It allows for reduction up to 60% in crushing time and the recovery of materials suitable for the type of operation desired, handling them in the best way.

PRIMARY SELECTION:

- WASTE MATERIAL
- DEMOLITION MATERIAL
- EXCAVATION FILLING MATERIAL
- STONY GROUND RECLAIM
- PEBBLES IN STREAMS
- DEBRIS IN BEACHES
- NATURAL STONE S CLEANING

AREAS OF APPLICATION

- RECYCLING
- LARGE-SCALE RESIDENTIAL SITES
- LARGE-SCALE COMMERCIAL SITES
- DEMOLITION
- FOUNDRIES
- INDUSTRY
- QUARRIES
- MINES

ACCESSORIES

- RECOMMENDED SPARE PARTS KIT
- HOUR METER
- 24 MONTHS WARRANTY

SPECIFICATIONS

EQUIPMENT	LOAD CAPACITY	BASKET DEPTH	GRID DIAMETER	DIMENSIONS
 ≥ 12 ≤ 25 Ton	2,40 m ³	1220 mm	1600 mm	2355 x 2180 H 1790 mm
OIL FLOW	PRESSURE	COUNTER PRESSURE DRAIN	WEIGHT	SPEED/MIN.
120 l/min.	220 bar	-	2,80 Ton	15/25 min/max