

MB-LS140

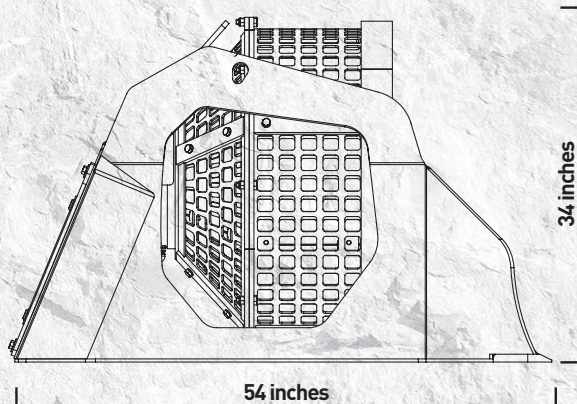

“Handy and efficient”

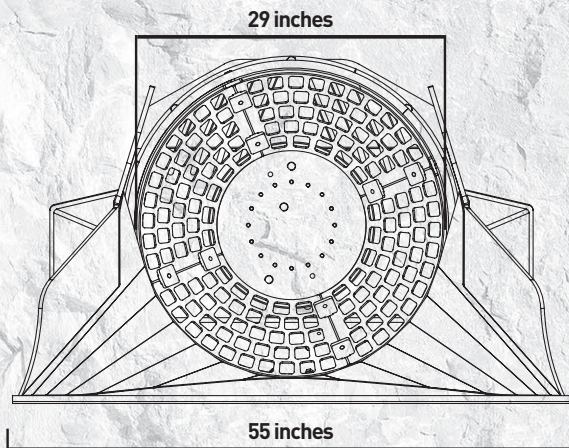
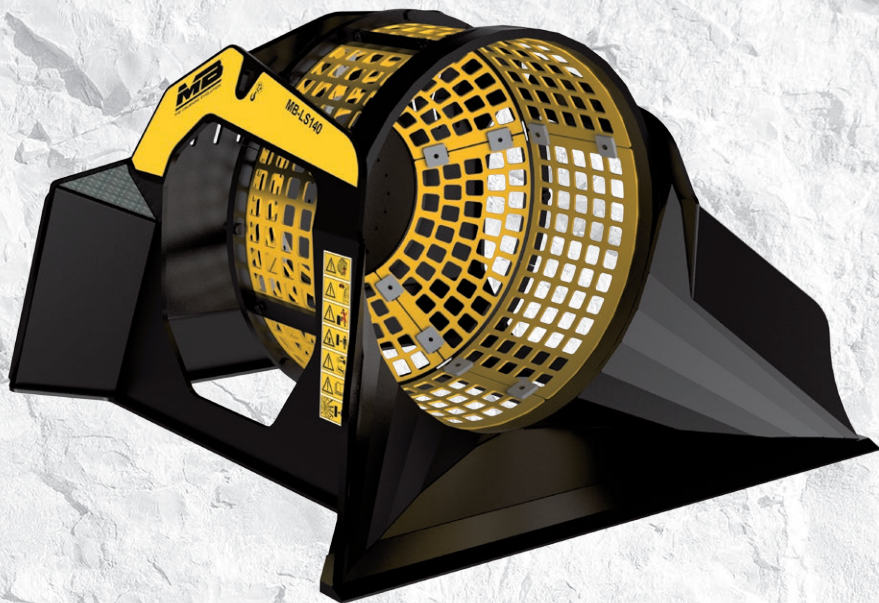
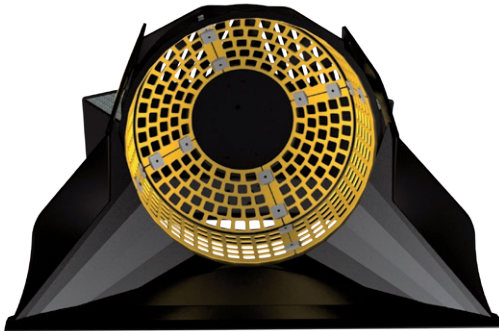

It's ideal for the selection of natural material in pre- and post-crushing. By screening the materials before crushing, the screening bucket MB-LS140 can reduce up to 60% of the time spent crushing. The MB-LS140 recovers the necessary material for the desired project and manages it in the best way.

The MB-LS140 is designed for loaders, skid loaders, and backhoes.



PRIMARY SELECTION:

- WASTE MATERIAL
- DEMOLITION MATERIAL
- EXCAVATION FILLING MATERIAL
- STONY GROUND RECLAIM
- PEBBLES IN STREAMS
- DEBRIS IN BEACHES
- NATURAL STONE S CLEANING

SPECIFICATIONS

EQUIPMENT	LOAD CAPACITY	BASKET DEPTH	GRID DIAMETER	DIMENSIONS
SKID LOADER ≥ 5,700 lbs	0.66 cy	21 in	29 in	54" x 55" x 34" H in
OIL FLOW	PRESSURE	COUNTER PRESSURE DRAIN	WEIGHT	RPM
14 gal /min.	2,176 PSI	-	1,000 lbs	25/30 min/max

ACCESSORIES

RECOMMENDED SPARE PARTS KIT	FIXED COUPLER	QUICK FEMALE COUPLER	HOOR METER	
MBS100015	-	-	804MBBV01	
				OPTIONAL 24 MONTHS WARRANTY
				WA241402

The data provided above is not binding, as the manufacturer reserves itself the right to make improvements to its products at any time and with no advance notice. References to excavator weights are approximate and many may be subject to changes. Consider a 20% tolerance.