

MB-L200 S2

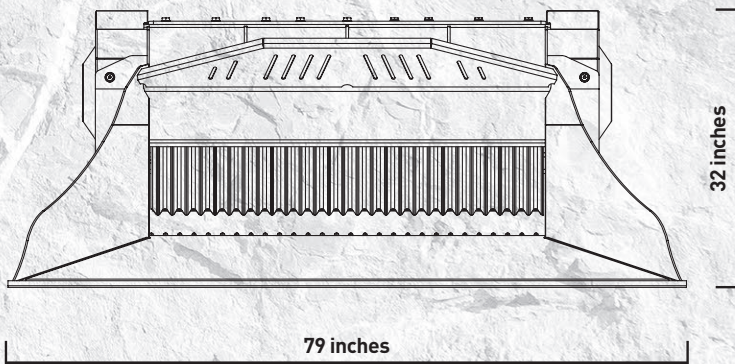

“The crusher bucket **changes shape**”

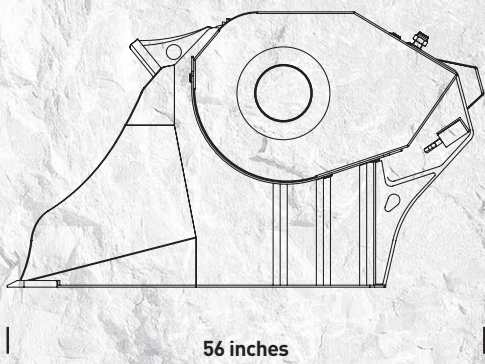

As the largest model of the MB-L line, the MB-L200 S2 was designed on the basis of specific work requirements for skid loaders and backhoes.

MB-L200 S2 crusher is suitable for skid loaders starting at a machine weight of 13,200 pounds and backhoe loaders starting a machine weight between 15,400 and 22,000 pounds. It has a mouth opening of 45" W x 10" H in and a production rate from 13 cy/h to 29 cy/h.

Changing the shape of the crusher does not affect the high performance and resistance of MB products.



AREAS OF APPLICATION

- DEMOLITION
- RECYCLING
- ROAD WORKS
- EXCAVATION

SPECIFICATIONS

EQUIPMENT	LOAD CAPACITY	OPENING DIMENSIONS	OUTPUT SETTING	DIMENSIONS
SKID LOADER ≥ 13,200 lbs BACKHOE LOADER / LOADER 15,400-22,000 lbs	0.58 cy	45" W x 10" H in	≥ 0.5 in ≤ 2.5 in	56" x 79" x 32" H in
OIL FLOW	PRESSURE	COUNTER PRESSURE	WEIGHT	MAXIMUM PRODUCTION
32 gal/min.	2,900 PSI	< 145 PSI	3,418 lbs	29 cy/h

ACCESSORIES

RECOMMENDED SPARE PARTS KIT	FIXED COUPLER	QUICK FEMALE COUPLER	IRON SEPARATOR	HOURLY METER
MBL160020	-	-	-	804MBNF01
			DUST SUPPRESSION KIT	OPTIONAL 24 MONTHS WARRANTY
			KNMB00L-KNMB00S-KNMB00M	WA242000

The data provided above is not binding, as the manufacturer reserves itself the right to make improvements to its products at any time and with no advance notice. References to excavator weights are approximate and many may be subject to changes. Consider a 20% tolerance.