

MB-L160 S2

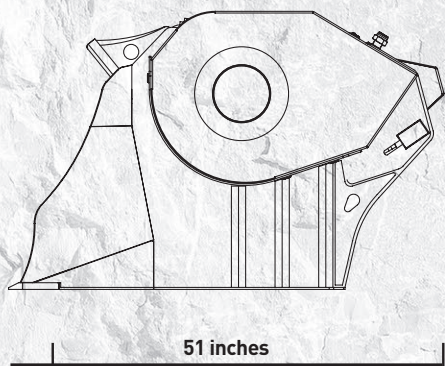

51 inches

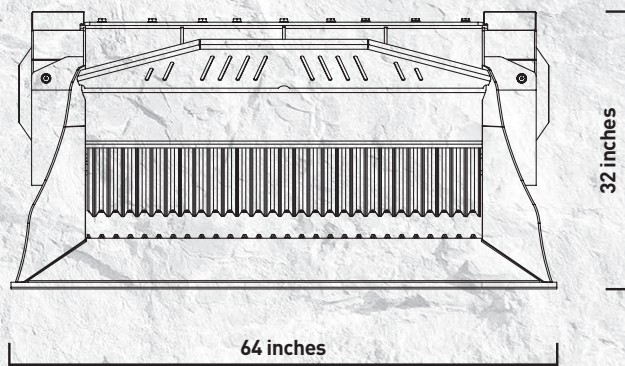

32 inches

64 inches

“Practical, handy, and **efficient**”



It's the perfect combination of efficiency and mobility. It was designed to meet the needs of skid loaders and backhoe loaders.

The MB-L160 S2 crusher bucket is suitable for skid loaders starting at a machine weight of 9,900 pounds and backhoe loaders starting at a machine weight between 15,400 and 22,000 pounds.

It has a load capacity of 0.45 cubic yards and a production rate from 12 cy/h to 26 cy/h.

The compact size is efficient and easy to use.



AREAS OF APPLICATION

DEMOLITION
RECYCLING
ROAD WORKS
EXCAVATION

SPECIFICATIONS

EQUIPMENT	LOAD CAPACITY	OPENING DIMENSIONS	OUTPUT SETTING	DIMENSIONS
SKID LOADER ≥ 9,900 lbs BACKHOE LOADER / LOADER 15,400-22,000 lbs	0.45 cy	44" W x 10" H in	≥ 0.5 in ≤ 2.5 in	51" x 64" x 32" H in
OIL FLOW	PRESSURE	COUNTER PRESSURE	WEIGHT	MAXIMUM PRODUCTION
30 gal/min.	2,900 PSI	< 145 PSI	2,977 lbs	26 cy/h

ACCESSORIES

RECOMMENDED SPARE PARTS KIT	FIXED COUPLER	QUICK FEMALE COUPLER	IRON SEPARATOR	HR METER
MBL160020	-	-	-	804MBNF01
			DUST SUPPRESSION KIT	OPTIONAL 24 MONTHS WARRANTY
			KNMB00L-KNMB00S-KNMB00M	WA241600

The data provided above is not binding, as the manufacturer reserves itself the right to make improvements to its products at any time and with no advance notice. References to excavator weights are approximate and many may be subject to changes. Consider a 20% tolerance.