

MB-L120 S2

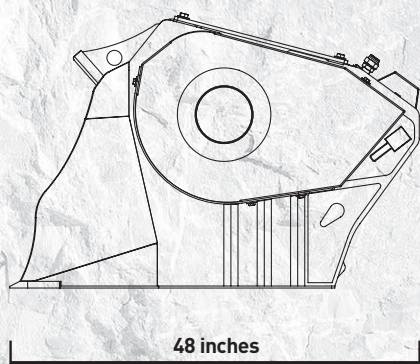

48 inches

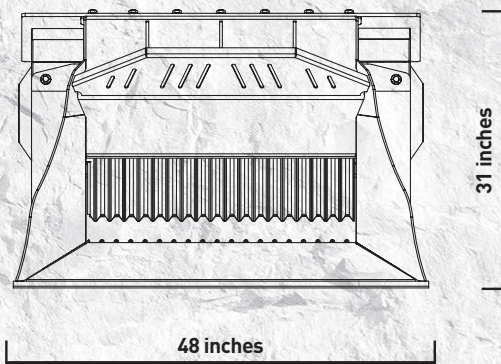

31 inches

48 inches

“Great in its little”



It's small but packed with high performance, and it meets the need that arises in small yards and limited spaces.

The MB-L120 S2 crusher bucket is suitable for skid loaders starting at a machine weight of 6,200 pounds and backhoe loaders starting at a machine weight between 11,000 and 15,500 pounds.

It has a load capacity of 0.25 cubic yards and a production rate from 8 cy/h to 18 cy/h.

Easy to carry, compact, handy, easy to use, and low maintenance.



AREAS OF APPLICATION

- DEMOLITION
- RECYCLING
- ROAD WORKS
- EXCAVATION

SPECIFICATIONS

EQUIPMENT	LOAD CAPACITY	OPENING DIMENSIONS	OUTPUT SETTING	DIMENSIONS
SKID LOADER ≥ 6,200 lbs BACKHOE LOADER / LOADER 11,000-15,500 lbs	0.25 cy	29" W x 10" H in	≥ 0.5 in ≤ 2.5 in	48" x 48" x 31" H in
OIL FLOW	PRESSURE	COUNTER PRESSURE	WEIGHT	MAXIMUM PRODUCTION
25 gal/min.	2,900 PSI	< 145 PSI	2,095 lbs	18 cy/h

ACCESSORIES

RECOMMENDED SPARE PARTS KIT	FIXED COUPLER	QUICK FEMALE COUPLER	IRON SEPARATOR	HOURLY METER
MBL140015	-	-	-	804MBNF01
			DUST SUPPRESSION KIT	OPTIONAL 24 MONTHS WARRANTY
			KNMB00L-KNMB00S-KNMB00M	WA241201

The data provided above is not binding, as the manufacturer reserves itself the right to make improvements to its products at any time and with no advance notice. References to excavator weights are approximate and many may be subject to changes. Consider a 20% tolerance.