

MB-G900

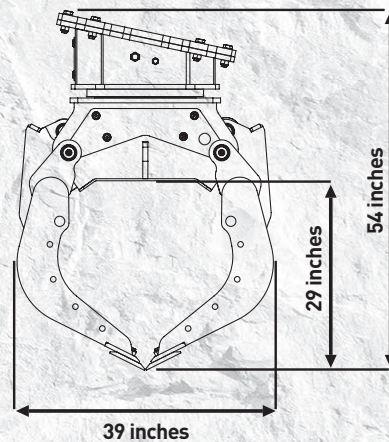

“Handy with high performance”

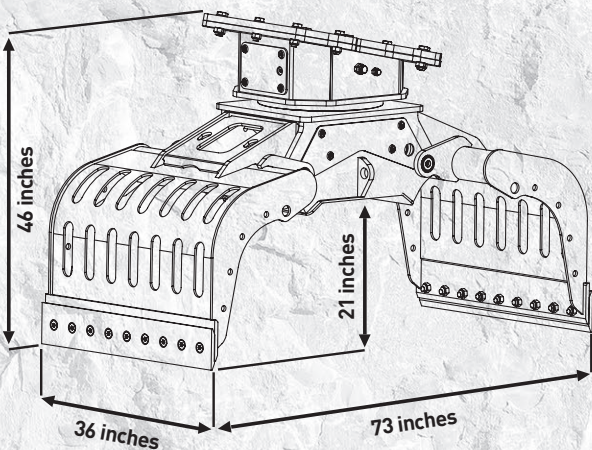

Designed for selecting and handling demolition materials and manufactured according to the highest technological standards for any type of materials in a reliable way.

Thanks to the interchangeable claws and the 360° hydraulic rotation, it allows you to handle large loads and odd forms with certainty and total safety.

SPECIFICATIONS

RECOMMENDED EXCAVATOR	LOAD CAPACITY (CLAWS CLOSED)		OIL FLOW (OPEN/CLOSE)
26,000-39,600 lbs	15 ft ³		8 gal/min.
PRESSURE (OPEN/CLOSE)	WEIGHT		ROTATION
2,900 PSI / 5,800 PSI	1,650 lbs		360°

ACCESSORIES

RECOMMENDED SPARE PARTS KIT	FIXED COUPLER	QUICK FEMALE COUPLER	
MBG900008	FCG690000	MBG690000	
			OPTIONAL 24 MONTHS WARRANTY
			WA240900