

MB-C50 S2

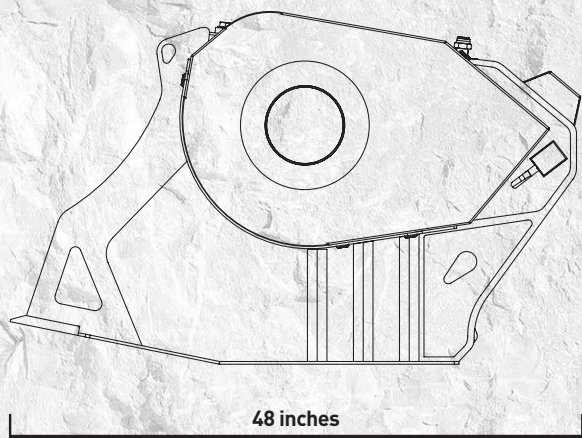

48 inches

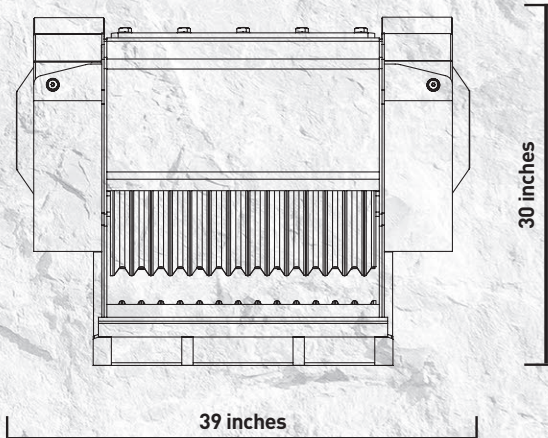

39 inches

30 inches

“MB’S little work of magic”



The MB-C50 is the smallest crusher bucket in the MB product line, weighting 1,654 lbs and designed to work on excavators starting from 8,800 lbs. It is suitable for mini excavators and great for small crushing jobs.

Due to its reduced size and weight, the MB-C50 has proven to be particularly useful in landscaping and restricted areas, ensuring high performance in small size with a production rate from 5 cy/h to 13 cy/h, depending on the output adjustment.



AREAS OF APPLICATION

DEMOLITION
ROAD WORKS
RECYCLING
EXCAVATION

SPECIFICATIONS

RECOMMENDED EXCAVATOR	LOAD CAPACITY	OPENING DIMENSIONS	OUTPUT SETTING	DIMENSIONS
≥ 8,800 lbs	0.19 cy	22" W x 10" H in	≥ 0.5 in ≤ 2.5 in	48" x 39" x 30" H in
OIL FLOW	PRESSURE	COUNTER PRESSURE	WEIGHT	MAXIMUM PRODUCTION
24 gal/min.	2,900 PSI	< 145 PSI	1,654 lbs	13 cy/h

ACCESSORIES

RECOMMENDED SPARE PARTS KIT	FIXED COUPLER	QUICK FEMALE COUPLER	IRON SEPARATOR	HR METER
BF5000010	FC5000000	BF5000000	-	804MBNF01
			DUST SUPPRESSION KIT	OPTIONAL 24 MONTHS WARRANTY
			KNMB00L-KNMB00S-KNMB00M	WA245000