

# BF 150.10

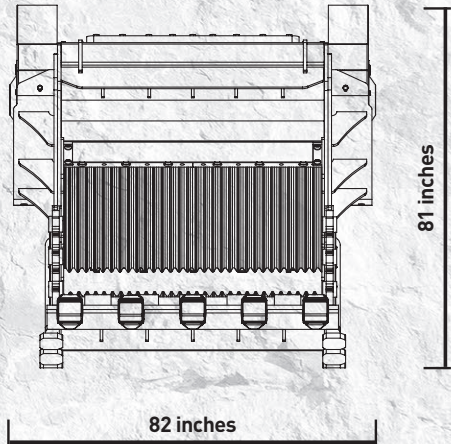

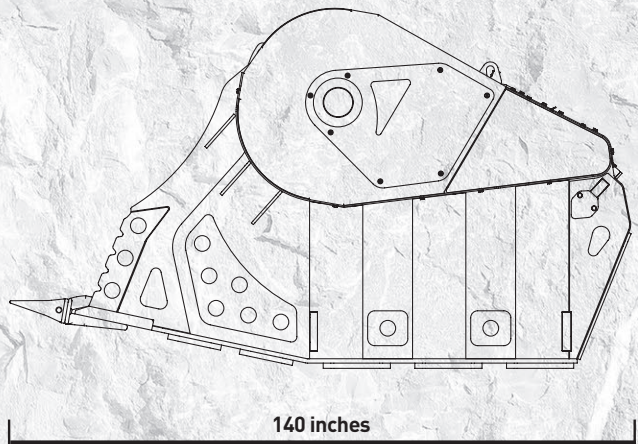

# “The records bucket”



Unique of its kind in size and performance, the BF 150.10 is the largest crusher bucket in the world. Designed for excavators exceeding 154,000 pounds and ideal for applications in quarry, mining, and general crushing on large job sites, the BF 150.10 crusher bucket yields high results, productivity, and efficiency.

Weighting over 23,000 pounds with a load capacity of 3.00 cubic yards, the BF 150.10 crusher bucket is a machine capable of a production rate from 96 cy/h to 157 cy/h.

With an unmatched bucket opening of 57" W x 28" H in and an output adjustment from 4.5-inch to 8-inch minus, this machinery is essential for primary crushing in quarries and large scale operations.

## AREAS OF APPLICATION

- QUARRIES
- MINES
- DEMOLITION
- RECYCLING
- EXCAVATION

## SPECIFICATIONS

| RECOMMENDED EXCAVATOR | LOAD CAPACITY | OPENING DIMENSIONS | OUTPUT SETTING    | DIMENSIONS            |
|-----------------------|---------------|--------------------|-------------------|-----------------------|
| ≥ 154,000 lbs         | 3.00 cy       | 57" W x 28" H in   | ≥ 4.5 in ≤ 8.0 in | 140" x 82" x 81" H in |
| OIL FLOW              | PRESSURE      | COUNTER PRESSURE   | WEIGHT            | MAXIMUM PRODUCTION    |
| 100 gal/min.          | 3,336 PSI     | < 145 PSI          | 23,150 lbs        | 157 cy/h              |

## ACCESSORIES

| RECOMMENDED SPARE PARTS KIT | FIXED COUPLER | QUICK FEMALE COUPLER | IRON SEPARATOR       | OUR METER                   |
|-----------------------------|---------------|----------------------|----------------------|-----------------------------|
| BF1501015                   | FC1510000     | -                    | -                    | 804MBNF01                   |
|                             |               |                      | DUST SUPPRESSION KIT | OPTIONAL 24 MONTHS WARRANTY |
|                             |               |                      | -                    | WA2415010                   |

The data provided above is not binding, as the manufacturer reserves itself the right to make improvements to its products at any time and with no advance notice. References to excavator weights are approximate and many may be subject to changes. Consider a 20% tolerance.