

BF 120.4 S2

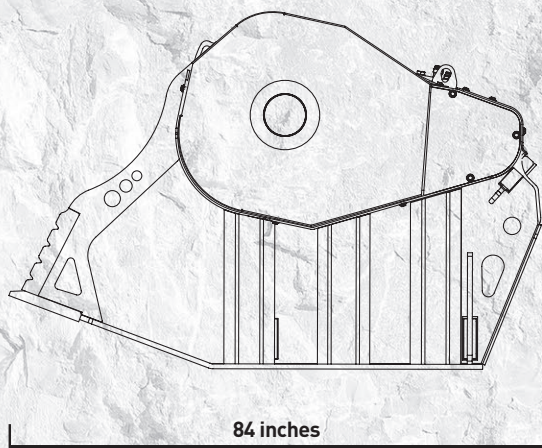

84 inches

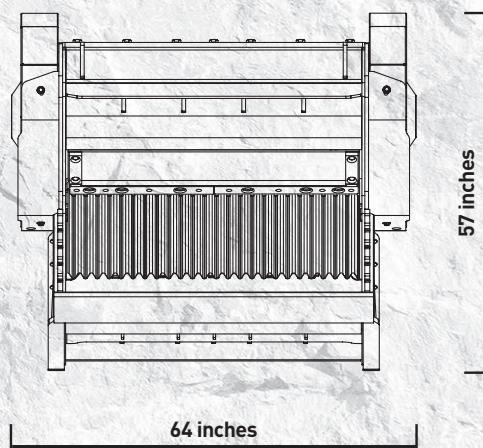

57 inches

64 inches

“Ideal for large projects”



A large bucket to ensure great results for construction projects. The BF 120.4 S2 is suitable for excavators weighing more than 68,300 pounds. It was created to meet the specific needs of crushing in quarries and landfills for aggregate recycling, and in large job sites to reduce the volume of materials resulting from demolition work.

With a production rate from 20 cy/h to 65 cy/h depending on the output adjustment, a capacity of 1.70 cubic yards, and a total weight of 10,803 pounds, the BF 120.4 S2 crusher bucket is an effective machine that has established itself as the premier crusher in the crushing field in just a few years.



AREAS OF APPLICATION

QUARRIES
DEMOLITION
RECYCLING
EXCAVATION
MINES
ROAD WORKS

SPECIFICATIONS

RECOMMENDED EXCAVATOR	LOAD CAPACITY	OPENING DIMENSIONS	OUTPUT SETTING	DIMENSIONS
≥ 68,300 lbs	1.70 cy	48" W x 21" H in	≥ 0.75 in ≤ 5.0 in	84" x 64" x 57" H in
OIL FLOW	PRESSURE	COUNTER PRESSURE	WEIGHT	MAXIMUM PRODUCTION
59 gal/min.	3,120 PSI	< 145 PSI	10,803 lbs	65 cy/h

ACCESSORIES

RECOMMENDED SPARE PARTS KIT	FIXED COUPLER	QUICK FEMALE COUPLER	IRON SEPARATOR	OUR METER
BF1240030	FC1240000	BF1204000	BF1240028	804MBNF01
			DUST SUPPRESSION KIT	OPTIONAL 24 MONTHS WARRANTY
			KNMB00L-KNMB00S-KNMB00M	WA241204

The data provided above is not binding, as the manufacturer reserves itself the right to make improvements to its products at any time and with no advance notice. References to excavator weights are approximate and many may be subject to changes. Consider a 20% tolerance.