

MB-S18 S3

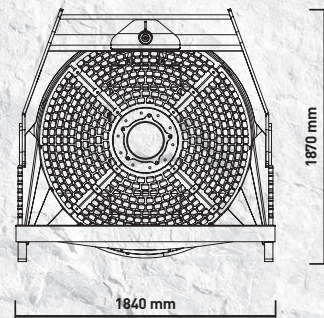

“Great performance”

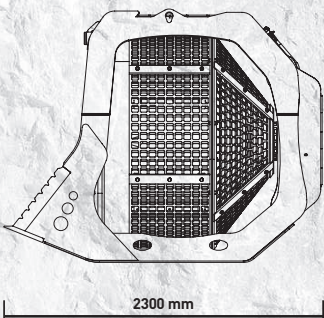
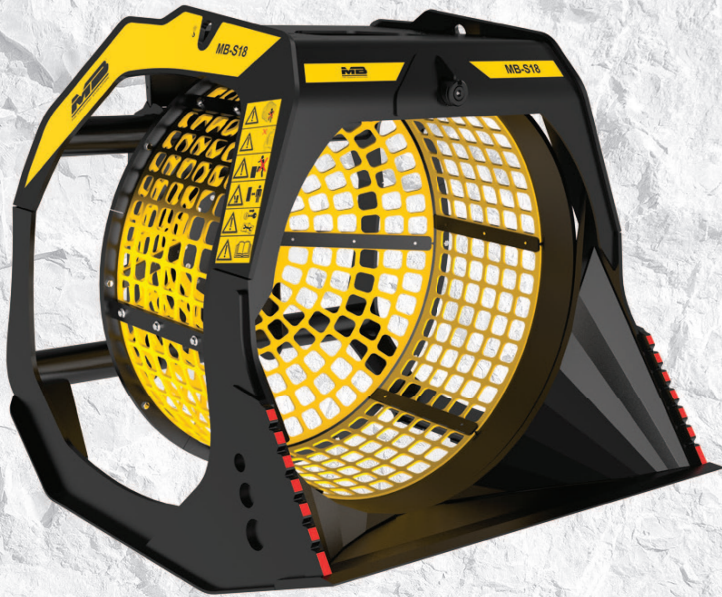

Suitable for large excavators between 20 to 35 Ton, the MB-S18 S3 is great for screening various kinds of material with outstanding performance.

Ideal for use before, or after crushing, the MB-S18 S3 screening bucket will reduce crushing time up to 60%. It also allows the screening of natural material (quarry residue, dry soil, and river stone) of any kind, making it convenient for on-site processing.

MB-S18 S3 screening bucket gives the opportunity to be implemented with the kit magnet and the nebulizer kit, increasing the versatility for the separation of iron, as well as allowing their use in inhabited centers due to suppression of dust.

A must in reducing volumes and optimizing the size of materials for specific uses.

The screening buckets MB are equipped with baskets formed by interchangeable modular panels, available with holes of different sizes based on requirements.

PRIMARY SELECTION:

- WASTE MATERIAL
- DEMOLITION MATERIAL
- EXCAVATION FILLING MATERIAL
- PEBBLES IN STREAMS
- DEBRIS IN BEACHES
- NATURAL STONES CLEANING

SPECIFICATIONS

RECOMMENDED EXCAVATOR	LOAD CAPACITY	BASKET DEPTH	GRID DIAMETER	DIMENSIONS
≥ 20 < 35 Ton	2,40 m ³	1200 mm	1600 mm	2300 x 1840 H 1870 mm
OIL FLOW	PRESSURE	COUNTER PRESSURE DRAIN	WEIGHT	SPEED/MIN.
120 l/min.	200 bar	-	2 Ton	25/35 min/max

ACCESSORIES

RECOMMENDED SPARE PARTS KIT	FIXED COUPLER	QUICK FEMALE COUPLER	HOUR METER	IRON SEPARATOR
MBS160002	FC1800000	MBS180000	804MBBV01	MBS160027
DUST SUPPRESSION KIT				24 MONTHS WARRANTY
KNMB00L-KNMB00S-KNMB00M				WA241800