

BF 80.3

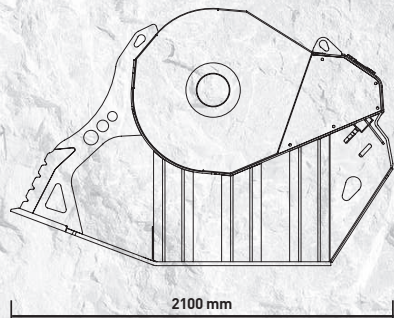

2100 mm

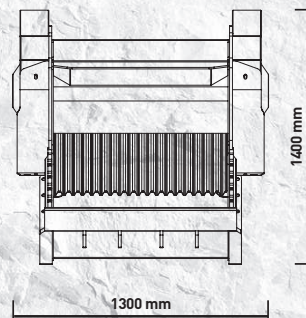

1400 mm

1300 mm

“Light and reliable”



Suitable for excavators that exceed 18.5 Ton of weight, the crusher bucket BF 80.3 is compact, versatile and suitable for the operations of crushing and recycling of inert material or resulting from demolition (road works - excavations - pipes - pipelines).

In spite of its size and lower weight compared to larger models, it reaches productivity of 34 m³ per hour.

AREAS OF APPLICATION

- QUARRIES
- DEMOLITION
- RECYCLING
- EXCAVATION
- MINES
- ROAD WORKS

SPECIFICATIONS

RECOMMENDED EXCAVATOR	LOAD CAPACITY	OPENING DIMENSIONS	OUTPUT SETTING	DIMENSIONS
≥ 18,5 Ton	0,70 m ³	L 840 H 510 mm	≥ 15 ≤ 135 mm	2100 x 1300 H 1400 mm
OIL FLOW	PRESSURE	COUNTER PRESSURE	WEIGHT	MAXIMUM PRODUCTION
160 l/min.	230 bar	10 bar	3Ton	34 m ³ /h

ACCESSORIES

RECOMMENDED SPARE PARTS KIT	FIX COUPLER	QUICK FEMALE COUPLER	IRON SEPARATOR	HOOR METER
BF8030010	FC8030000	BF8030000	BF8030017	804MBNF01
			DUST SUPPRESSION KIT	24 MONTHS WARRANTY
			KNMB00L-KNMB00S-KNMB00M	WA248030