

# MB-G1 000 S4

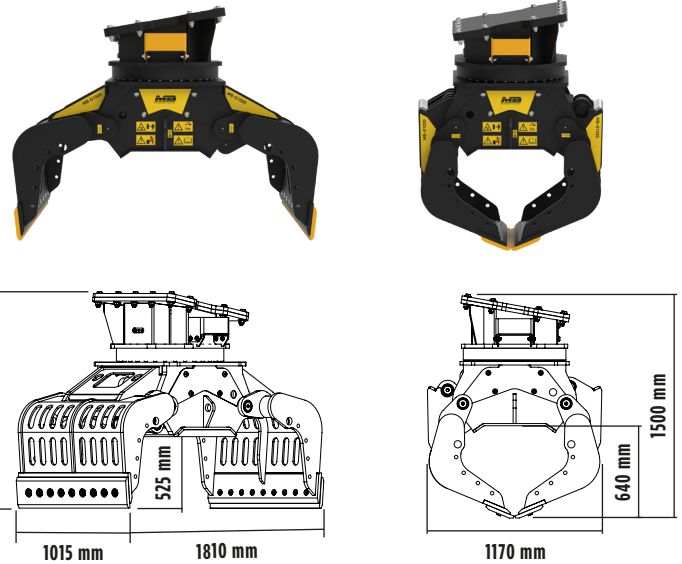

## ACCESORIOS OPCIONALES

- REMOTE POWER CONTROL SYSTEM
- GARANTÍA DE 24 MESES

## CARACTERÍSTICAS TÉCNICAS

EXCAVADORA ACONSEJADA	≥ 18 ≤ 25 ton
PESO	1,62 ton
CAPACIDAD (GARRAS CERRADAS)	0,44 m <sup>3</sup>
ROTACIÓN	360° Grados
PRESIÓN DEL ACEITE (ROTACIÓN)	> 220 bar
CAUDAL DE ACEITE (ROTACIÓN)	40 ÷ 70 l/min
PRESIÓN DEL ACEITE (APERTURA/CIERRE)	300 ÷ 400 bar
CAUDAL DE ACEITE (APERTURA/CIERRE)	70 l/min.

## ÁREAS DE APLICACIÓN



OBRAS URBANAS



DEMOLICIONES



OBRAS VIALES



GALERIAS



AMBIENTES CERRADOS



CANALIZACIONES



CANTERAS



MINAS



MANTENIMIENTO DE ÁREAS VERDES Y AGRÍCOLAS



MANTENIMIENTO DE ÁREAS FORESTALES